

LINER PROTRUSION EVALUATION

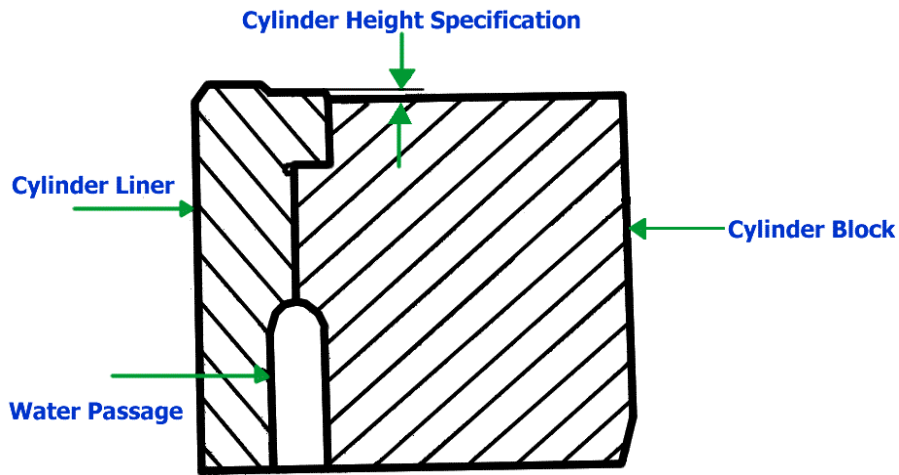

NAME

DATE

PROJECT

SPECIFICATIONS

Liner Protrusion

Cylinder Liner	Point 1	Point 2	Point 3	Point 4	Difference In Height	Comments
1						
2						
3						
4						
5						
6						
7						
8						

Instructor's Initials