

SYSTEM FUNCTIONAL SCHEMATIC (CAB)

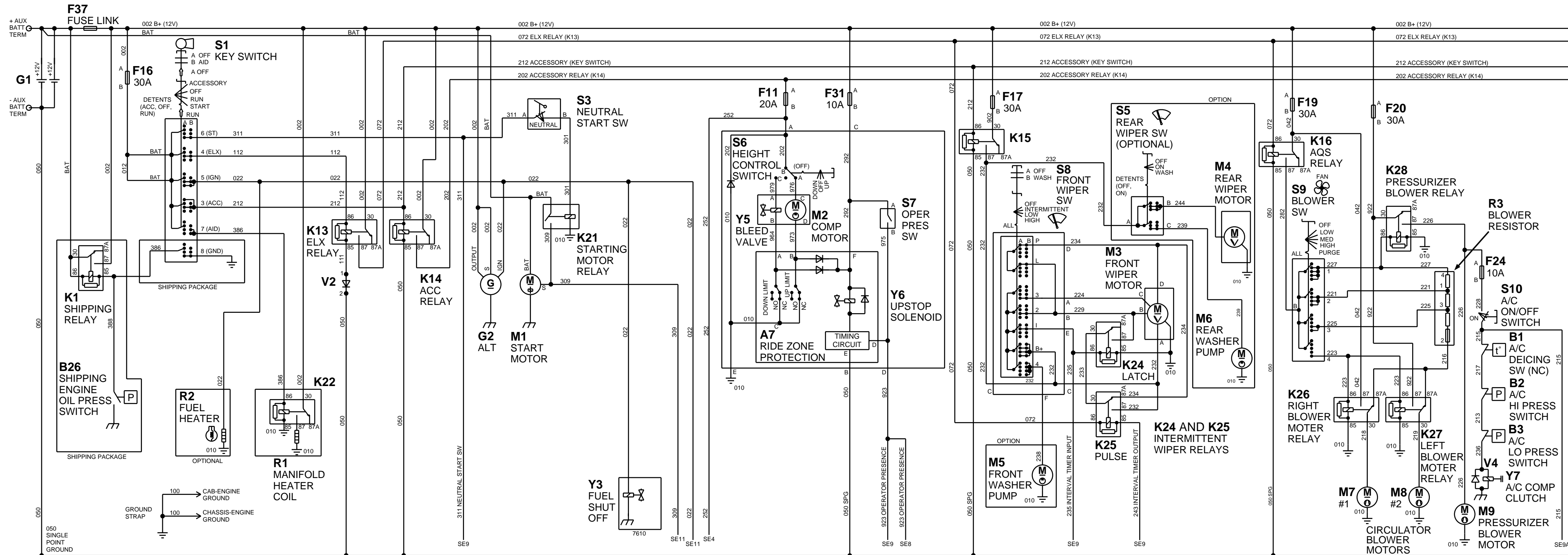

RW70649