

Ag Power and Equipment Technician

Electrical/Electronic Class
Series Circuits – Lab 2

Name _____

Date _____

Competency: Understanding series circuit characteristics.

Directions: Using our color coding strategy, highlight this circuit, then have your instructor sign off the job sheet. Then build the circuit shown below on the electrical trainer. Make the following measurements to complete this job sheet.

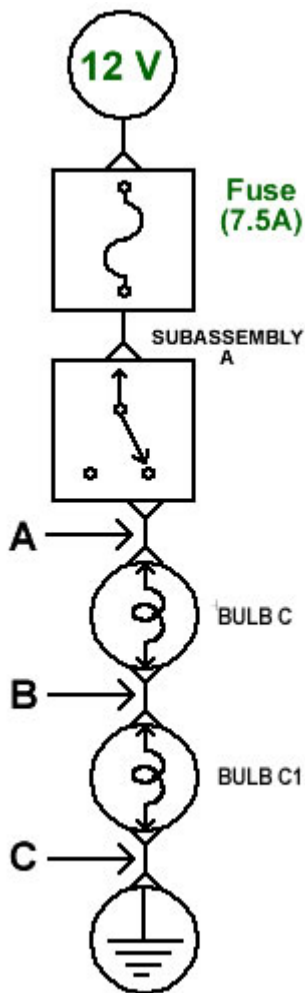

Voltage drop across Bulb C	
Voltage drop across Bulb C1	
Voltmeter red lead to 12v source, black lead to location A	
Voltmeter red lead to 12v source, black lead to location B	
Why is this voltage different from that measured in step 3?	
Source Voltage	
Total Current	
Amps	
Milliamps	
Calculate total circuit resistance	

Instructor's Initials